

4

3

2

1

REVISIONS - 2 BALLOONS DENOTE CHANGES			
REV.	DESCRIPTION	DATE	APPROVED
A		6/19/2019	
B	MATERIAL WAS PREVIOUSLY A380	8/21/2019	ZAG
B	ADDED ID MARK LOCATION	8/23/2019	ZAG

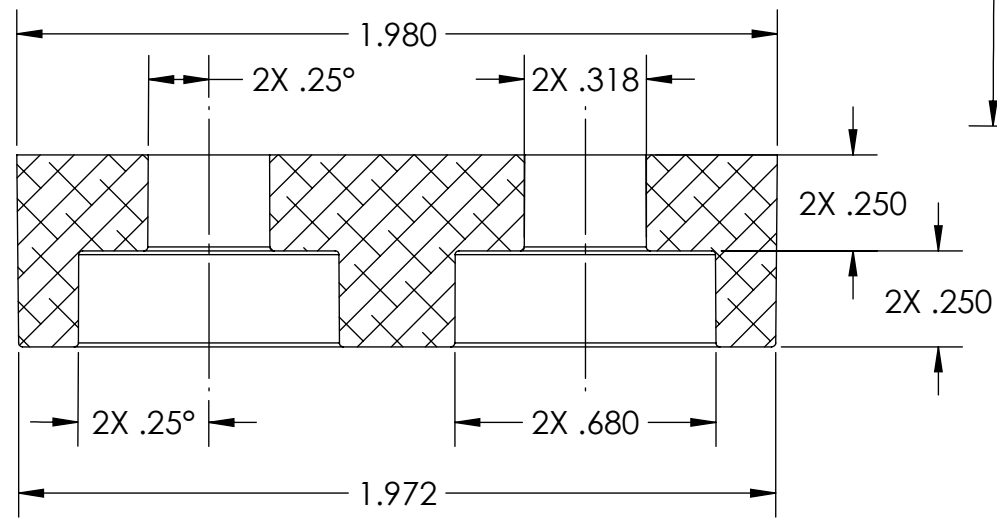
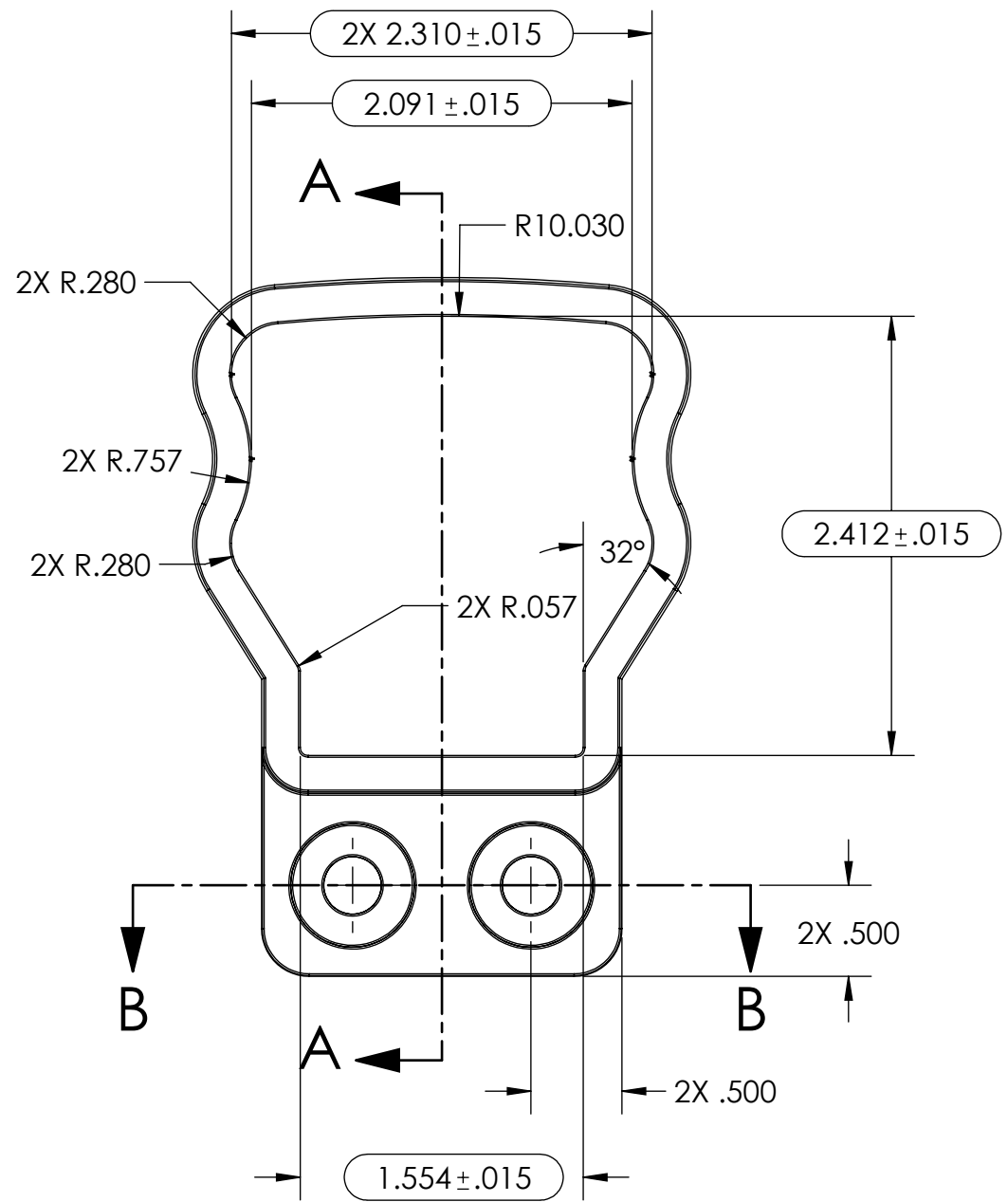

SECTION B-B

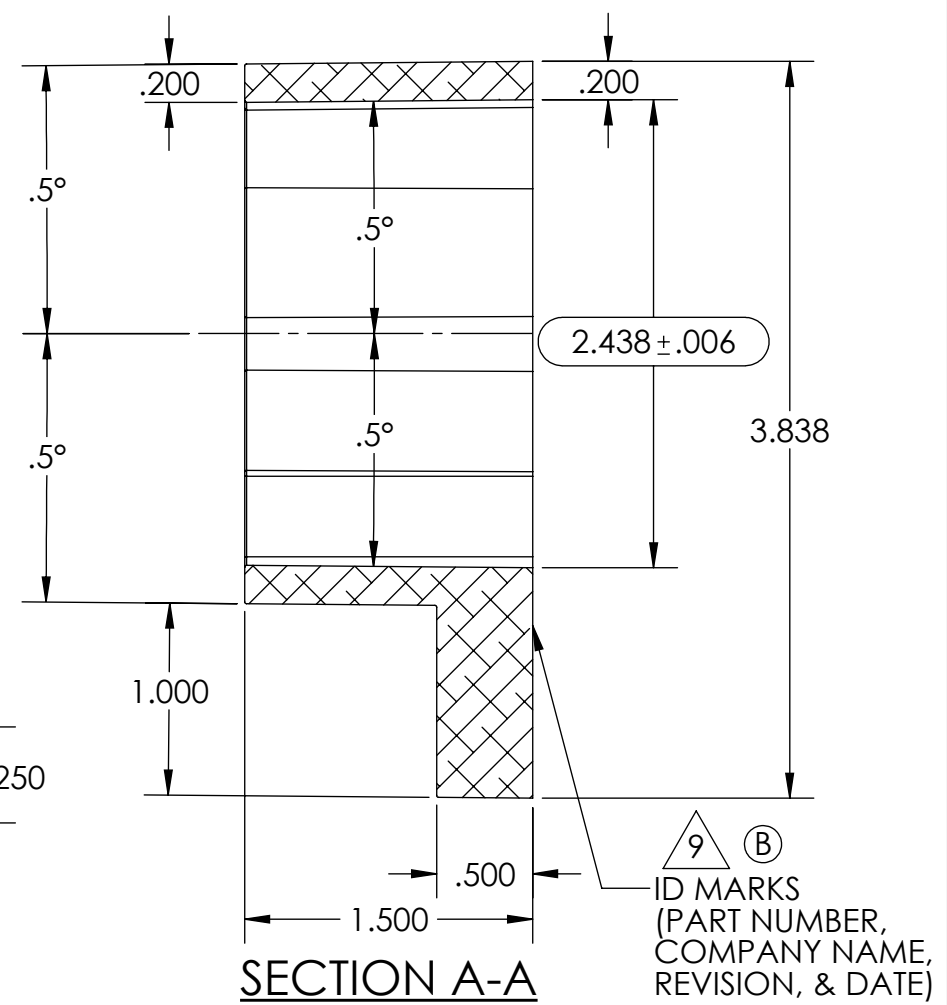

SECTION A-A

- NOTES:
- UNSPECIFIED DIMENSIONS AND DRAFT ANGLES ARE PER 3D CAD MODEL. THE MODEL IS THE MASTER.
 - MUST BE FREE FROM FLASH AND SHARP EDGES.
 - NOMINAL WALL THICKNESS .200".
 - INDICATES A CRITICAL DIMENSION.
 - STANDARD DRAFT ANGLE IS .5 DEG UNLESS STATED OTHERWISE.
 - ALL GATE AND EJECTOR PIN LOCATIONS TO BE APPROVED BY ULTRALOX PRIOR TO DIE MANUFACTURE.
 - DIMENSIONS APPLY BEFORE PAINT OR COATINGS, INSPECT PARTS BARE.
 - ALL UNSPECIFIED RADII MAX .010".
 - DEBOSS VERBIAGE IF NEEDED TO KEEP FROM STICKING OUT BUT ALSO ENSURE VERBIAGE DOES NOT SHOW THROUGH TO FINISHED SIDE.

UNLESS OTHERWISE SPECIFIED:		NAME	DATE
DIMENSIONS ARE IN INCHES		DRAWN	DRC 6/19/19
TOLERANCES:		CHECKED	
SURFACE FINISH: 125 RMS		ENG APPR.	
ANGULAR: .5°		MFG APPR.	
TWO PLACE DECIMAL ± .020			
THREE PLACE DECIMAL ± .010			
INTERPRET GEOMETRIC TOLERANCING PER:	THIRD ANGLE PROJECTION:		
MATERIAL	A369	PROPRIETARY AND CONFIDENTIAL THE INFORMATION CONTAINED IN THIS DRAWING IS THE SOLE PROPERTY OF UltraLox. ANY REPRODUCTION IN PART OR AS A WHOLE WITHOUT THE WRITTEN PERMISSION OF UltraLox IS FORBIDDEN.	
FINISH	-	SIZE	DWG. NO.
DO NOT SCALE DRAWING		B	CC29400

ULTRALOX
INTERLOCKING TECHNOLOGY

TITLE:
**FABRICATION DRAWING,
COLONIAL WALL MOUNT
CASTING**

REV **B**

WEIGHT: SHEET - OF -

4

3

2

1